



Wireless and wired headset communication systems for pushback, deicing, ramp operations and aircraft maintenance



AIRLINE/AIRPORT
GROUND SUPPORT
COMMUNICATION SOLUTIONS



WWW.DAVIDCLARK.COM

DAVID CLARK GROUND SUPPORT COMMUNICATION SYSTEMS

Even the slightest miscommunication can have catastrophic and expensive consequences during ground support operations. That's why major airlines around the world rely on our communication solutions. Our durable, quality-made headsets and related system components provide clear communications during push back, deicing and ground maintenance operations.

David Clark Company wireless and wired headset communication systems ensure safety and enhance efficiency for all ramp personnel.



WIRELESS SERIES 9900



WIRELESS MOBILITY PROMOTES SAFETY FOR GROUND SUPPORT OPERATIONS

David Clark Series 9900 Wireless Headset Communication Systems provide maximum mobility allowing ramp crew members the freedom to move about without being tethered to the aircraft or related equipment during ground support operations. A variety of durable headsets, belt stations and gateways let users choose the right equipment that best fits their application. All components are designed and built to the highest quality standards for rugged yet comfortable long-term use and reliable performance.



SYSTEM COMPONENTS: HEADSETS

H9935

*Over-the-Head Style • Mic Boom
Noise Reduction Rating: 26 dB
Maximum durability for all ramp and maintenance operations*

Over-molded flex boom assembly, non-rotating, for precise microphone positioning and rugged reliability



Features

- Four-chamber, air-flow pillow head pad for outstanding comfort
- Marine-grade stainless steel hardware for rugged durability
- Dual, water-tight volume controls on domes
- Undercut, Comfort-Gel ear seals cradle the ear for secure yet comfortable fit

H9930

*Over-the-Head Style • Mic Boom
Noise Reduction Rating: 23dB
Ideal for tug operators, ramp agents, deicing crews*



H9910

*Over-the-Head Style • Muff Mic
Noise Reduction Rating: 26 dB
Perfect for maintenance or ramp operations*



More info? Complete wireless headset listing and specifications



WIRELESS SERIES 9900

PUSHBACK OPERATIONS: GATEWAY

The U9920-GPB Push-Back Gateway is designed specifically for seamless integration with aircraft interphone systems. It acts as a relay for all intercom audio between multiple Wireless Belt Station/Headset users and the interphone system for pilot to ground communications.



Features

- Hands-free, full-duplex intercom communication
- DECT-based technology provides secure signaling and prevents unwanted 'cross talk'
- Accommodates up to four (4) users simultaneously connected with audio
- Marine-grade, water-tight, impact-resistant enclosure for rugged durability and reliability
- High-visibility orange skin for added impact protection (oil, water, UV resistant)
- Requires aircraft interface cord. See available interface cords at www.davidclark.com/wireless
- EU version available: U9920-GPB (EU)



More info? Complete specifications for all Series 9900 Gateways and Belt Stations



PUSHBACK OPERATIONS: BELT STATIONS

Belt stations transmit and receive audio, to and from the gateway and user's headset, while eliminating extraneous noise from critical communications.

U9910-BSW

Ideal for tug operators working with wing walkers



- Hands-free, full-duplex, voice-activated (VOX) intercom communication
- EU version available: U9910-BSW (EU)

U9913-BSW

Designed for wing walkers/ramp agents



- Same as U9910-BSW except no PTT transmit capability outside the intercom (radio, flight deck, etc.)
- EU version available: U9913-BSW (EU)

Features

- Accommodates any Series 9900 wireless headset
- DECT-based technology provides secure signaling and prevents unwanted 'cross talk'
- Marine-grade, water-tight, impact-resistant enclosure for rugged durability and reliability
- Voice prompts confirm link, range and battery status
- Rubberized outer skin provides impact protection and is oil, water and UV resistant (color varies by model)

SIMPLE PUSHBACK INTERCOM SYSTEM



WIRELESS SERIES 9900



DEICING OPERATIONS

The Series 9900 Wireless Communication System is ideal for deicing operations — with or without a radio. Improved communication between deicer cab and bucket results in more productive and efficient application of costly deicing fluids, and helps prevent accidental aircraft damage.



DEICING INTERCOM CONFIGURATION (WITH RADIO)

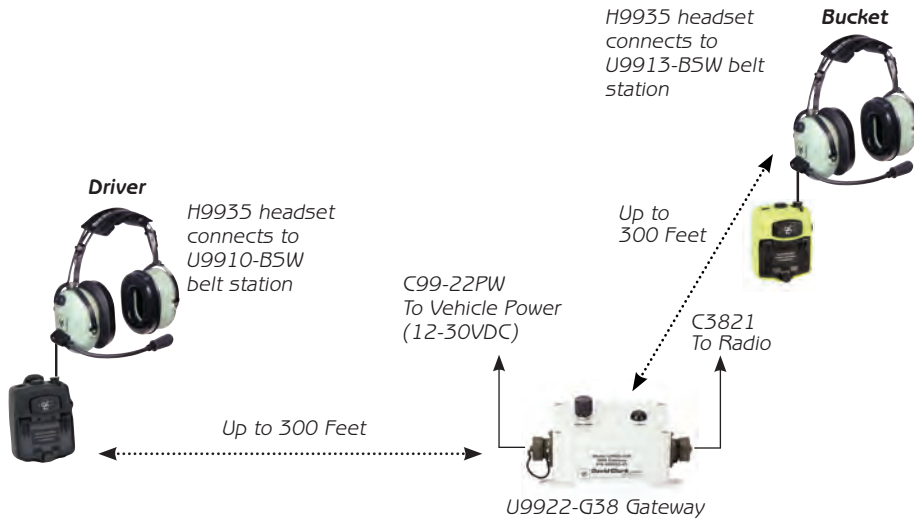

U9922-G38 GATEWAY



- Serves as a relay for hands-free intercom between driver and bucket position
- Provides interface to mobile radio inside cab
- Allows users to hear all radio traffic, those with radio PTT-enabled belt stations transmit over radio
- EU version available: U9922-G38 (EU)

DEICING INTERCOM CONFIGURATION (WITHOUT RADIO)

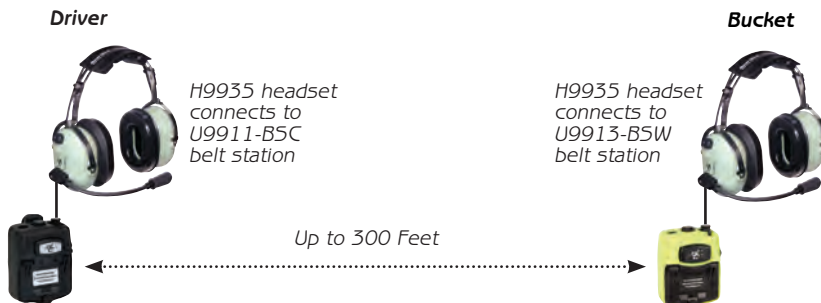

U9911-B5C CONTROLLER



- U9911-B5C Controller Belt Station serves as a 'master control' to which all belt stations within a ground support or deicing crew are linked
- Accommodates one wireless headset itself and acts as a relay for all intercom audio between multiple wireless belt stations
- EU version available: U9911-B5C (EU)

BATTERY CHARGER: A99-14CRG



- Accommodates 4 each Li-Polymer Batteries
- LED indicators for individual charge status
- Fully charge battery cell in 3-4 hours

AC Power Cord Kits:

- C99-14AC1 (110VAC)
- C99-14AC2 (230VAC)



Li-Polymer batteries provide up to 24 hours continuous use when fully charged.

Note: Chargers are not sealed units, and are not intended for installation in wet or corrosive environments.

PUSHBACK SERIES 3000 HEADSETS (WIRED)

David Clark **Series 3000** Headsets, Extension Cords and Adapter Cords provide quality communications **in wired system ground support applications**. A variety of noise attenuating headsets, including over-the-head, single ear and muff microphone models offer reliable performance and superior comfort while enhancing communication and safety during all aspects of ramp operations.



PUSHBACK OPERATIONS

H3530



Features

- Flex boom allows for perfect microphone placement
- DC-1A noise-cancelling amplified dynamic microphone
- Straight cord (30 in.) with locking connector to mate with C35-XX Series Belt Station
- Corrosion-resistant, chrome-plated headband/stirrup assembly
- Certified Noise Reduction Rating (NRR): 24 dB

C35-XX (length)

Series Belt Station

Interfaces the H3530 headset to aircraft. momentary push-to-talk (PTT) switch prevents background noise from interfering with communications prior to and during pushback. Available with either straight or coil cords in lengths from 8 to 30 feet.



- C35 Series Belt Station available as C35-16 and C35-30 straight cord, or C35-08 and C35-26 extended coil cord (number after dash indicates cord length in feet)

H3331



Features

- Wire boom allows microphone placement on right or left side
- DC-1A noise-cancelling amplified dynamic microphone
- Soft head pad and foam-filled ear seals ensure comfort
- Corrosion-resistant, chrome-plated headband/stirrup assembly
- Certified Noise Reduction Rating (NRR): 24 dB

- Momentary PTT switch on ear dome
- 15-ft. straight cord mates with C31-12, C31-25, C31-50 and C31-100 straight extension cords (number after dash indicates cord length in feet)

H3335



- Microphone on/off switch on ear dome
- 26-ft. coil cord mates with C31-12, C31-25, C31-50 and C31-100 straight extension cords (number after dash indicates cord length in feet)

More info? Complete Series 3000 headset listing and specifications



DE-ICING 3800 SYSTEM (WIRED)



DE-ICING COMMUNICATIONS (WIRED)

The Series 3800 System is designed to provide communication solutions and enhance safety during aircraft de-icing, anti-icing and maintenance operations.

- Improves communication between de-icer cab and bucket, resulting in more productive application of costly de-icing fluids
- Helps to prevent accidental damage to aircraft during de-icing operations
- Enhances efficiency and safety while saving time during de-icing operations

SERIES 3800 HEADSETS

H3332

Dual Ear

Typically Used by Bucket Operator



Features

- DC-1A noise-cancelling amplified dynamic microphone
- Microphone on/off switch allows hands-free communication
- Soft head pad and foam-filled ear seals for added comfort
- 6-foot extended coil cord
- Certified Noise Reduction Rating (NRR): 24 dB

H3392

Single Ear

Typically Used by Driver in Cab



Features

- DC-1A noise-cancelling amplified dynamic microphone
- Soft, air-flow head pad and foam-filled ear seals and temple pad for added comfort
- 6-foot extended coil cord

SERIES 3800 POWER AND JUMPER CORDS

C3820

Power Cord



Two-conductor shielded, 20-ft. cord. Connects U3800 to power source. One end stripped and tinned for connection to truck battery or fuse rack.

C38-XX (length)

Jumper Cords, -25 ft., -35 ft., -50 ft.,
-75 ft., -100 ft. lengths



Four-conductor shielded cord with MS screw-on (pin) connectors. Connects U3800 to U3801. (Number after dash indicates length/feet)

SERIES 3800 DE-ICING SYSTEM CONFIGURATION

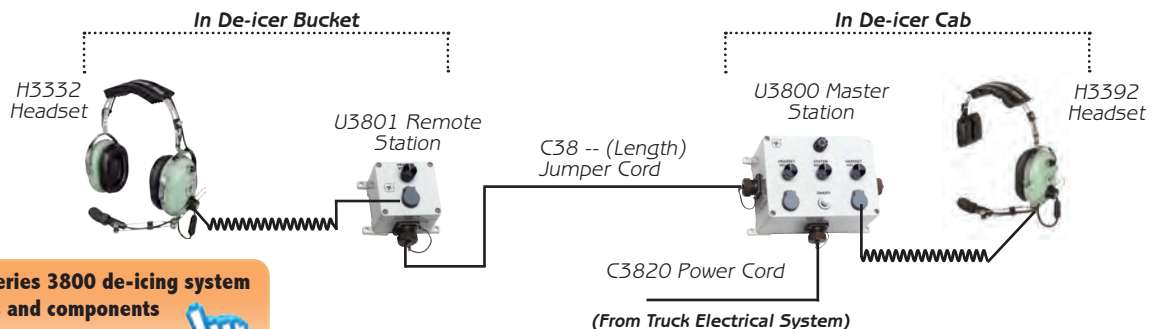

More info? View Series 3800 de-icing system headsets and components



SERIES 3000 HEADSETS (WIRED)

HEADSETS FOR RAMP/MAINTENANCE OPERATIONS

David Clark muff microphone style headsets are ideal for a variety of maintenance and ramp operations. Headsets feature noise-shielded microphone with momentary PTT switch.

H3310



- 30-inch straight cord, mates with C31-XX Series extension cords
- Snap-fastened nylon straps secure microphone muff to mouth

H3312



- 25-foot straight cord eliminates the need for extension cords
- Microphone muff hangs freely and ready for periodic use

H3313



- 30-inch straight cord, mates with C31-XX Series extension cords
- Microphone muff hangs freely and ready for periodic use



HEADSETS AND ADAPTERS FOR TWO-WAY RADIOS

David Clark noise-attenuating headsets with noise-cancelling microphones facilitate clear and effective reception and transmission on portable two-way radios. A variety of headset styles and configurations – with and without adapters – are available for virtually hundreds of two-way radio makes and models.



Series 6200 Radio Direct headsets connect directly to your two-way radio without the need for an adapter.



Series 6700 Intrinsically Safe Radio Direct headsets are also available for potentially hazardous operations such as refueling.

Use our online app to quickly find the right headset for your two-way radio



HEARING PROTECTORS

Basic hearing protection on extremely noisy airport ramps is a staple requirement to promote worker safety. David Clark offers a variety of quality hearing protectors designed for all-day comfort and built to stand up to harsh, everyday use.

MODEL 10A



- Adjustable headband and stirrup assembly assure long-term wearing comfort
- Noise Reduction Rating (NRR): 23 dB

MODEL 310



- "TRI-FIT" style - over-the-head, under-the-chin or behind-the-head
- Swivel action headband provides added flexibility for any application
- Noise Reduction Rating (NRR): Over-the-Head, 23 dB; Behind-the-Head, 20 dB; Under-the-Chin, 20 dB

SERIES 3000 EXTENSION CORDS (WIRED)

C31-XX SERIES EXTENSION CORDS

C31-XX Series Extension Cords mate with David Clark Series 3000 Noise-Attenuating Headsets to increase the distance between headsets and ground support connections when additional headset length is required. **Number after dash in model number indicates length in feet.**



C31-12, C31-25, C31-50, C31-100

Straight Cord



Coil Cord

C31-26 26-foot (extended), Coil Cord



Straight Cord

P/N 18253G-12 12-inch, Straight Cord, converts to U-174/U plug for special applications

'Y' ADAPTER CORDS



Straight Cord

A "Y" Cord Adapter is required to connect any David Clark Series 3000 Headset to aircraft that are equipped with two external jacks for access to the aircraft's intercom system. This addition makes the Series 3000 Headsets more versatile.

P/N 18253G-10 23-inch, Straight Cord with dual GA plugs



Straight Cord

P/N 18253G-15 23-inch, Straight Cord with two Female Connectors. Allows two headsets to be plugged in simultaneously. Ideal for training operations.

HIGH-VISIBILITY, "DAY-GLO" ORANGE EXTENSION CORDS

Ideal for airline/airport ground support, pushback and ramp maintenance operations. Designed for use with Series 3000 Headsets.

Model C31-15DG

15-foot (extended) Coil Cord with jack and retractable plug boot

Model C31-26DG

26-foot (extended) Coil Cord with jack and retractable plug boot



Coil Cord



David Clark Company Incorporated
360 Franklin Street
Worcester, MA 01604 U.S.A.
Tel. 508-751-5800

800-298-6235
WWW.DAVIDCLARK.COM



19544P-66 (10/20)